

Details on AIR containers and Pallets

Pallets are flat sheets of aluminum on which shipment pieces are stacked. Each pallet is usually covered with a net to secure loose pieces

AIR Containers

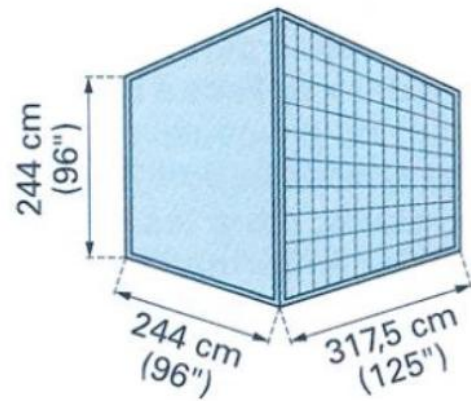
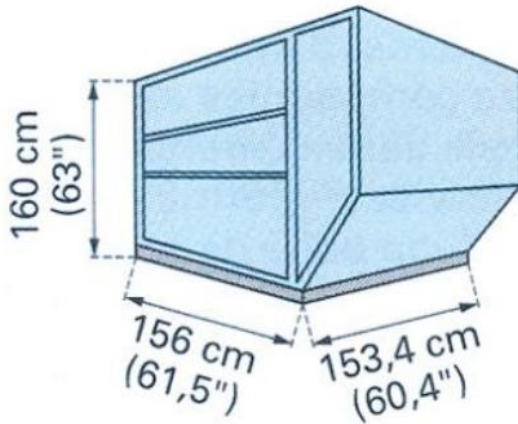

AIR Pallets

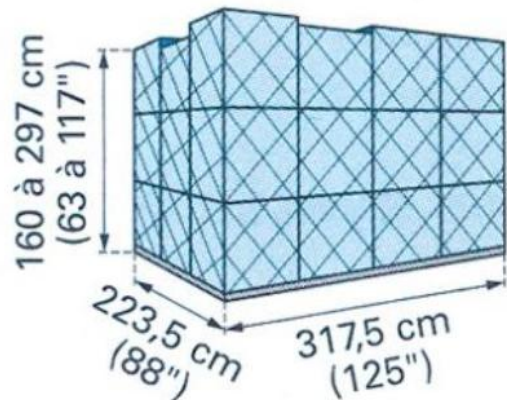
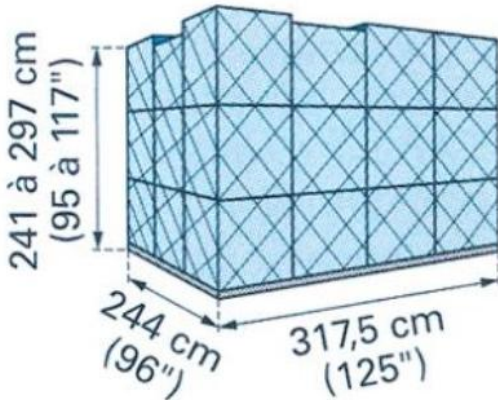

AAP 317,5 cm x 223,5 cm x 162,5 cm for a volume of 9,8 m³. This container can be transported in B747F, B740, A330 and B777 planes.

AAU (LD29) is the most important plane hold. Its important size and volume (465 cm x 215 cm x 150 cm for 14 m³) means that it can only be transported in BN747 aircrafts.

AKC (LD1) measure 220 cm x 140 cm x 155 cm is a rectangular model which can only be transported in big aircrafts holds.

AKE (LD3) is the most common model in aviation. It can be transported in long-haul but in all freighters too. It can

hold until 1587 kg. It can be charged on plane upper deck or be transported in hold of passengers flights.

AKH (156 cm x 153,4 cm x 114 cm) has a volume of 3,5 m³ that makes it the smallest of the most common models. It allows containerization in long-haul holds of A320 aircrafts.

AKN (156 cm x 153,4 cm x 160 cm) represent a volume of 3,9 m³. It cans be transported on board B747, A340 and A330 aircrafts.

AMA (M1) measure 317,5 cm x 244 cm x 244 cm and has a volume of 15,7 m³. It's the bigger common container. It's important size means that it can only be transported in B747 aircrafts

AMP (LD9) measure 317,5 cm x 244 cm x 162,5 cm for a volume of 10,8 m³. This model can be loaded on board of B747F, B747, A340, A330 and B777 aircrafts.

DPE/DPN (LD2) has a volume of 3,5 m³. It's one of the little containers that can be transported in B767 and B777 aircraft holds.

PAG or "88 inch pallet" (317,5 cm x 223,5 cm) is the most common model in flight freight, in B474F, B747, B777, A340 and A330. It can withstand until 4600 kg. It can be loaded on plane upper deck or travel on commercial flight hold.

PMC/MS or "96 inch pallet" (317,5 cm x 244 cm). This model has a more spacious capacity than the PAG one. It can be loaded on plane upper deck and in plane hold for the bigger planes. It can flight inside B747F, B747, B777, A340 and A330 planes.

PGA/PGF (M2) measures 606 cm x 244 cm and has a volume between 32 and 38,7 m³. This model is only loadable inside B747F nose door loading.

PZA/PRA or "95 inch pallet" (498 cm x 244 cm) constitute a volume between 26 and 31,8 m³. This model, like the previous one, is only loadable inside B747F nose door loading.

PKC (156 cm x 153,4 cm) has a volume equivalent to 3,5 m³. This model is compatible with A320 and A321 aircrafts.

PNA (243,8 cm x 156,2 cm) has a volume of 10,7 m³ and is only loadable on B767 aircraft.

PLB (LD5/LD11) measures 317,5 cm x 153,4 cm and correspond to a volume of 6,8 m³. This model can be transported onboard of A340 and A330 aircrafts.